

Memorandum to the City of Markham Committee of Adjustment

May 14, 2021

File: A/023/21
Address: 7 Voysey Way – Markham, ON
Applicant: Bharathiraja Sellamuthu
Agent: Varatha Design Associates
Hearing Date: May 26, 2021

The following comments are provided on behalf of the East Team.

The applicant is requesting relief from the following “Second Density Residential (RMD2)” requirements of By-law 90-81, as amended, as they relate to a proposed secondary suite (basement apartment), and parking reduction. The variances requested are to permit:

a) By-law 90-81, Section 5.2.1:

a Second Dwelling Unit, whereas the By-law permits not more than one Single Detached Dwelling on one lot;

b) By-law 2008-161, Section 7.52(2)(b):

A maximum of 43 dwelling units within the designated area of this By-law, whereas the By-law permits a maximum of 41 dwelling units within the designated area; and,

c) By-law 28-97, Section 3.0, Table A:

a minimum of two parking spaces, whereas a minimum of three parking spaces are required.

BACKGROUND

Property Description

The subject property is located on the east side of Voysey Way, south of Elson Street, east of Markham Road, and north of Steeles Avenue. The property is developed with a two-storey single detached dwelling, which backs on to an open space zone. Voysey Way is a private road which has a total of 14 visitor parking spaces shared between each of the dwellings located on site, according to the original 2008 approved Site Plan (Appendix “C”).

The property is located within a common element plan of condominium residential development containing two-storey detached and semi-detached dwellings. Located south of the condominium development is an open space area which includes a pond, walking trails and a woodlot, and further to the south, are single unit and multi-unit commercial buildings at the intersection of Steeles Avenue and Markham Road.

Proposal

The applicant is requesting permission for a secondary suite in the basement of the existing dwelling, and a parking reduction as a result of the additional dwelling unit. The proposed secondary suite would have direct access provided by an existing door located at the south side of the building, separate from the main door entry located at the same side. The basement level also includes three new egress windows located at the north, east (rear), and south sides of the building. No other changes are being proposed to the exterior of the dwelling, or the property.

The applicant's proposal to permit a secondary suite results in an increase to the maximum number of 41 dwelling units permitted within the designated area (residential plan of condominium). In 2017, the Committee of Adjustment ("the Committee") at the time approved a secondary suite for a separate property municipally addressed 307 Elson Street, which is located within the same plan of condominium as the subject property. While the property owner of 307 Elson Street obtained approval for a secondary suite, they did not make a request to permit a maximum of 42 dwelling units within the designated area.

The applicant is therefore requesting permission to increase the maximum number to 43 dwellings within the plan of condominium in order to retrospectively capture and recognize the approval of a secondary suite at 307 Elson Street, and the proposed secondary suite at 7 Voysey Way. With the variances proposed, staff confirm that the applicant would be limited to permitting one secondary suite on the subject property.

Provincial Policies

More Homes, More Choice Act, 2019

The *More Homes, More Choice Act, 2019*, S.O. 2019, c. 9 – (Bill 108), received Royal Assent on June 6, 2019 and portions were proclaimed on September 3, 2019. The proclaimed portions of Bill 108 amended the *Planning Act* to require Official Plans to contain policies providing for two residential units in detached, semi-detached, and rowhouse dwellings, as well as permitting a residential unit in ancillary structures to a detached, semi-detached, or rowhouse dwelling. Under this legislation, "second suites" or "secondary suites" are now referred to as "additional residential units", and the terms are used synonymously in this memorandum.

Provincial Policy Statement, 2020

Section 1.4.3 of the *Provincial Policy Statement, 2020*, requires planning authorities to provide for an appropriate range and mix of housing options and densities to meet the affordable housing needs of current and future residents. Amongst other means, this can be achieved by permitting and facilitating residential intensification, including additional residential units, and redevelopment by accommodating a significant supply and range of housing options through intensification and redevelopment while taking into account existing building stock.

A Place to Grow: Growth Plan for the Greater Golden Horseshoe, 2019 (Growth Plan, 2019)

Section 2.1.4 (c) of the *Growth Plan, 2019* requires municipalities to provide a diverse range and mix of housing options including second units to support complete communities.

Official Plan and Zoning

Official Plan 2014 (partially approved on November 24/17, and updated on April 9/18)

The Official Plan designates the subject property "Residential Low Rise", which provides for low rise housing forms including single detached dwellings. The Official Plan also contains criteria for the establishment of secondary suites in Section 8.13.8 which states:

"That in considering an application to amend the Zoning By-law to permit the establishment of a secondary suite where provided for in this Plan, Council shall be satisfied that an appropriate set of development standards are provided for in the Zoning By-law including:

- a) *the building type in which the secondary suite is contained;*
- b) *the percentage of the floor area of the building type devoted to the secondary suite;*
- c) *the number of dwelling units permitted on the same lot;*
- d) *the size of the secondary suite;*
- e) *the applicable parking standards; and*
- f) *the external appearance of the main dwelling.”*

A “Secondary Suite” in the Official Plan is defined as:

“...a second residential unit in a detached house, semi-detached house, or rowhouse that consists of one or more rooms designed, occupied or intended for use, including occupancy, by one or more persons as an independent and separate residence in which a facility for cooking, sleeping facilities and sanitary facilities are provided for the exclusive use of such person or persons.”

Section 4.1.2.6 of the Official Plan contains policies to support further diversification of the housing stock and rental housing tenure by permitting secondary suites within existing and new single detached, semi-detached, and rowhouse dwellings in accordance with Section 3.5.22 of the Regional Official Plan and subject to appropriate zoning, development criteria, and standards.

Zoning By-Law 90-81, as amended

The subject property is zoned “Second Density Residential (RMD2)” under By-law 90-81, as amended, which permits a single detached dwelling. The proposed development does not comply with the By-law requirements to permit a maximum of one single detached dwelling, and a maximum of 41 dwelling units on site.

Parking Standards By-law 28-97

The proposed development also does not comply with the Parking By-law with respect to the minimum requirement of three parking spaces.

Zoning Preliminary Review (ZPR) Not Undertaken

The applicant has confirmed that a ZPR has not been conducted. However, the applicant has received zoning comments from staff through their building permit process to confirm the variances required for the proposed development.

COMMENTS

The *Planning Act* states that four tests must be met in order for a variance to be granted by the Committee:

- a) The variance must be minor in nature;
- b) The variance must be desirable, in the opinion of the Committee, for the appropriate development or use of land, building or structure;
- c) The general intent and purpose of the Zoning By-law must be maintained;
- d) The general intent and purpose of the Official Plan must be maintained.

Secondary Suite

Fire and Emergency Services Department have no objections provided the secondary suite is registered with the City and complies with Building and Fire Codes. Should this application be approved, the applicant will be required to obtain a building permit which

ensures the secondary suite will be in compliance with Building Code and Fire Code regulations, and will be required to register their secondary suite with the Fire Department prior to the occupancy of the unit.

The City of Markham is committed to promoting affordable and shared housing opportunities. Secondary suites help the City increase the availability of affordable housing forms and provide support to achieve its affordable housing target required by the Province. Planning staff are of the opinion that the application meets the criteria under Section 8.13.8 of the Official Plan for the establishment of a secondary suite, and therefore have no objections.

Maximum Dwelling Units

As previously stated, the applicant's proposal to permit a secondary suite results in an increase to the maximum number of 41 dwelling units permitted within the designated area (residential plan of condominium). The applicant is proposing that the maximum number of 43 dwelling units be permitted on site to recognize the proposed secondary suite, and previously approved secondary suite of a separate minor variance application.

Reduction in Parking

The Parking By-law requires two parking spaces for the single detached dwelling, and one additional parking space for the accessory basement apartment. The applicant is proposing two existing parking spaces on the subject property, whereas the By-law requires three parking spaces.

Staff have reviewed the original Site Plan and note that dwellings are situated on parcels of tied land (POTL's) which means that the private road (Voysey Way), and onsite visitor parking areas are owned by the condominium corporation.

A site visit was conducted by Planning staff on March 16, 2021, which confirmed that visitor parking areas as identified by the existing signage are to be used by visitors only, and any unauthorized vehicles would be tagged and, or towed at the owners expense. The applicant should also be aware that no parking is permitted along Voysey Way. According to the original 2008 Site Plan, Voysey Way has a right-of-way width of 6.0 m (19.69 ft) at its narrowest point, and is a required fire route, which is to be free from parked vehicles at all times in order to provide for safe, and unimpeded access along all points of the fire route. The applicant has confirmed that the condominium corporation was notified of the minor variance application, and has further provided staff with written confirmation that the condominium corporation has no objections to the requested variances.

In providing support for this parking reduction, staff are of the opinion that the parking issue may be considered "self-regulating", as the accessory dwelling unit would only be of interest to an occupant that does not require a parking space, in the event that both parking spaces are required for use by the owner of the subject property.

PUBLIC INPUT SUMMARY

No written submissions were received as of May 21, 2021.

It is noted that additional information may be received after the writing of the report, and the Secretary-Treasurer will provide information on this at the meeting.

CONCLUSION

Planning staff have reviewed the application with respect to Section 45(1) of the *Planning Act, R.S.O. 1990, c. P.13, as amended*, and are of the opinion that the variance request meets the four tests of the *Planning Act*. Staff recommend that the Committee consider public input in reaching a decision.

The onus is ultimately on the applicant to demonstrate why they should be granted relief from the requirements of the By-law, and how they satisfy the tests of the *Planning Act* required for the granting of minor variances.

Please see Appendix "A" for conditions to be attached to any approval of this application.

APPENDICES

Appendix "A" – Conditions of Approval

Appendix "B" – Plans

Appendix "C" – Original Site Plan: September 30, 2008

PREPARED BY:



Aleks Todorovski, Planner, Zoning and Special Projects

REVIEWED BY:



Stacia Muradali, Development Manager, East District

APPENDIX "A"

CONDITIONS TO BE ATTACHED TO ANY APPROVAL OF FILE A/023/21

1. The variances apply only to the proposed development as long as it remains.
2. That the variances apply only to the proposed development, in substantial conformity with the batch stamped plans attached as Appendix "B" to this Staff Report, and that the Secretary-Treasurer receives written confirmation from the Director of Planning and Urban Design or designate that this condition has been fulfilled to his or her satisfaction.
3. That the owner submit, if required by the Chief Building Official, a third-party report prepared by an architect or professional engineer licensed in the Province of Ontario, to assess compliance of existing construction with the provisions of the Ontario Building Code, and in particular relating to the change of use from a dwelling containing a single suite to a dwelling containing more than one suite.

CONDITIONS PREPARED BY:



Aleks Todorovski, Planner, Zoning and Special Projects

APPENDIX "B"
PLANS TO BE ATTACHED TO ANY APPROVAL OF FILE A/023/21

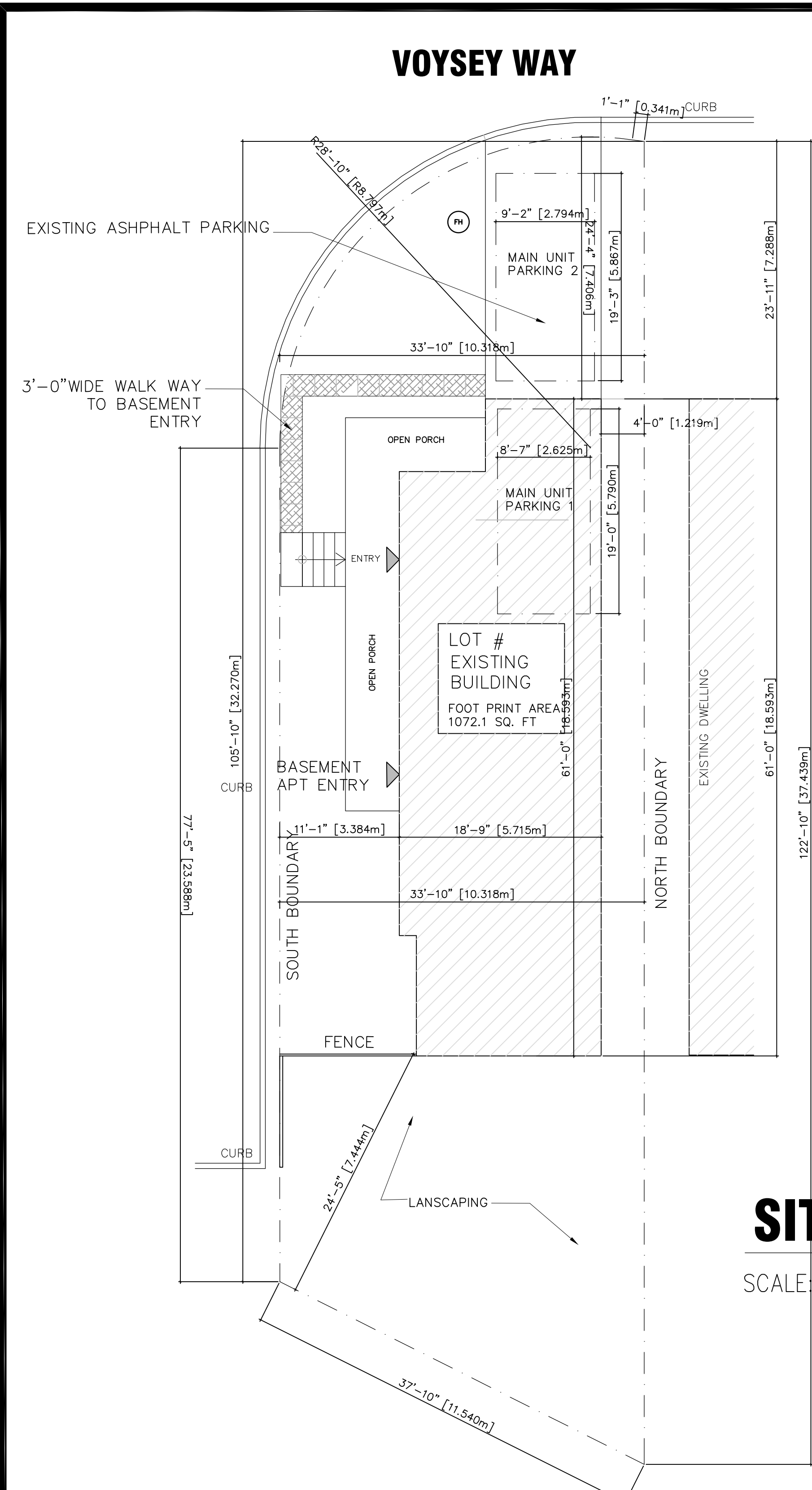

SITE STATISTICS:

SITE ADDRESS: 7 VOYSEY WAY, MARKHAM
 LOT AREA: 3703.1 square ft= (344.15 SQ.M.)
 GROUND FLOOR SPACE : 1072.06 SF (99.95 SM)
 SECOND FLOOR SPACE : 1009.8 SF (93.84 SM)
 BASEMENT SECOND UNIT AREA : 618.5 square ft. (57.48 SM)

SITE PLAN

SCALE 3/32" = 1'-0"

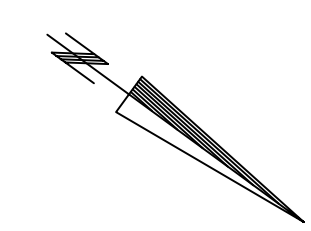

THE UNDERSIGNED HAS REVIEWED AND TAKES RESPONSIBILITY FOR THIS DESIGN, AND HAS THE QUALIFICATIONS AND MEETS THE REQUIREMENTS SET OUT IN THE O.B.C TO BE A DESIGNER

QUALIFICATION INFORMATION:
 KRANAGAVARATHA (B.C.I.N) 26147

REGISTRATION INFORMATION:
 VARATHA DESIGN ASSOCIATES (B.C.I.N) 33937

DRAWING TITLE:	SITE PLAN
PROJECT:	NEW BASEMENT APT IN EXISTING DWELLING TO 7 VOYSEY WAY, MARKHAM
OWNER:	Bharathiraja Sellamuthu

ALL DRAWINGS AND RELATED DOCUMENTS ARE COPYRIGHT PROPERTY OF VARATHA DESIGN ASSOCIATES. AND MUST BE RETURNED UPON REQUEST. REPRODUCTION OF DRAWINGS AND RELATED DOCUMENTS IN PART OR WHOLE IS FORBIDDEN WITHOUT DESIGNER'S CONSENT IN WRITING.

DRAWINGS NOT TO BE SCALED
 CONTRACTOR MUST CHECK AND VERIFY ALL DIMENSIONS ON THE SITE AND REPORT ANY DISCREPANCIES OR ERRORS BEFORE COMMENCING ANY PART OF THE WORK

THE DESIGNER HAS NOT BE RETAINED TO CARRY OUT GENERAL REVIEW OF THE WORK AND ASSUMES NO RESPONSIBILITY FOR THE FAILURE OF THE CONTRACTOR OR SUBCONTRACTORS TO CARRY OUT THE WORK IN ACCORDANCE WITH THE CONTRACT DOCUMENTS

MYLARS/VELUMS ARE ISSUED TO THE CLIENTS ON THE UNDERSTANDING THAT NO CHANGES ARE TO BE MADE TO THE CONTRACT DOCUMENTS WITHOUT WRITTEN CONSENT OF THE DESIGNER.

NO.	REVISION/ISSUED TO	BY	DATE
2	Issued for COA	K.V.	MAR. 22/21
1	building permit	K.V.	FEB4,21

VARATHA DESIGN ASSOCIATES
 Architectural & Engineering Services
 Varatha Ken
 Designer
 TEL: (416) 284 7945
 CELL: (416) 725 2041
 TORONTO Ont. email: kvaratha@hotmail.com

SCALE: 1/8" = 1'-0"	CAD FILE :	JOB No.: 21141
DATE: FEB4,21	DWG NO: A1	OF 4
DRAWN BY: K.V.	CHECKED BY: K.V.	DATE OF PRINT: MAR. 22/21

NOTE:
 · SMOKE ALARM ON MAIN FLOOR IS INTERCONNECTED WITH SMOKE ALARM ON SECOND FLOOR AND BASEMENT.
 · SMOKE ALARM SHALL CONFIRM TO O.B.C. DIV. B 9.10.19
 EXISTING MAIN FLOOR WALL AND CEILING IS DRY WALL FILLED WITH INSULATION SOUND TRANSMISSION BETWEEN MAIN UNIT AND SECOND SUITE.
 SEE SECTION A-A

ALL SUPPLY AND RETURN AIR DUCTS ON EXTERIOR WALL TO BE FURRED OUT FOR CONT. INSULATION

SMOKE ALARM
 · SHALL HAVE A VISUAL SIGNALING COMPONENT INTEGRATED INTO THE SMOKE ALARM.
 · SHALL HAVE A BATTERY BACKUP

INSTALL 1/2" TYPE 'X' DRYWALL CEILING
 SEE SECTION A-A
 @ 84" A.F.F
 FULL BASEMENT AND 80" U/D BEAMS

ALL SUPPLY AND RETURN AIR TO BE 18" AFF

(N1) ADD 1 LAYER 5/8" TYPE "X" AROUND ST'L COLUMN ENCASED IN WALL TYPE P3

(N2) 1 LAYER 5/8" TYPE "X" AROUND ST'L BEAM BASED ON TABLE T 2.3.12 C/W MINERAL WOOL 45 MIN.

(N3) INSTALL 5/8" TYPE "X" DRY WALL UNDERSIDE OF STAIRS CEILING BASED ON TABLE 2.3.4A SB-2 MIN 40 MIN F.R. JOISTS EQ. 10 MIN = 50 MIN TOTAL

61'-0" [18.593m]

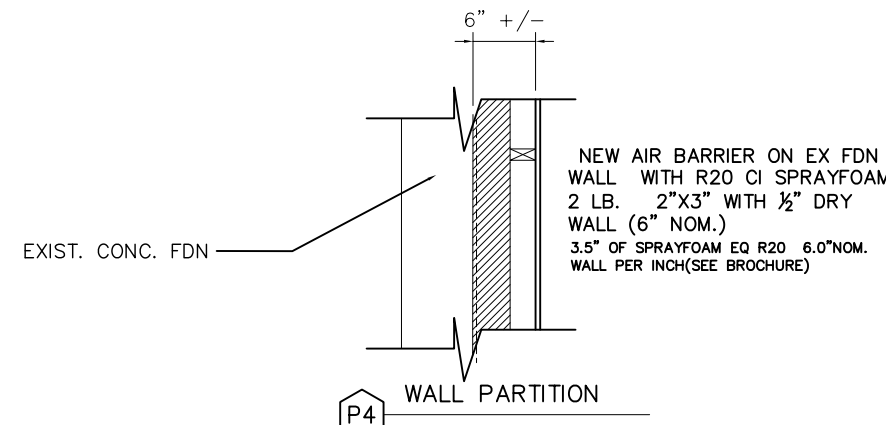
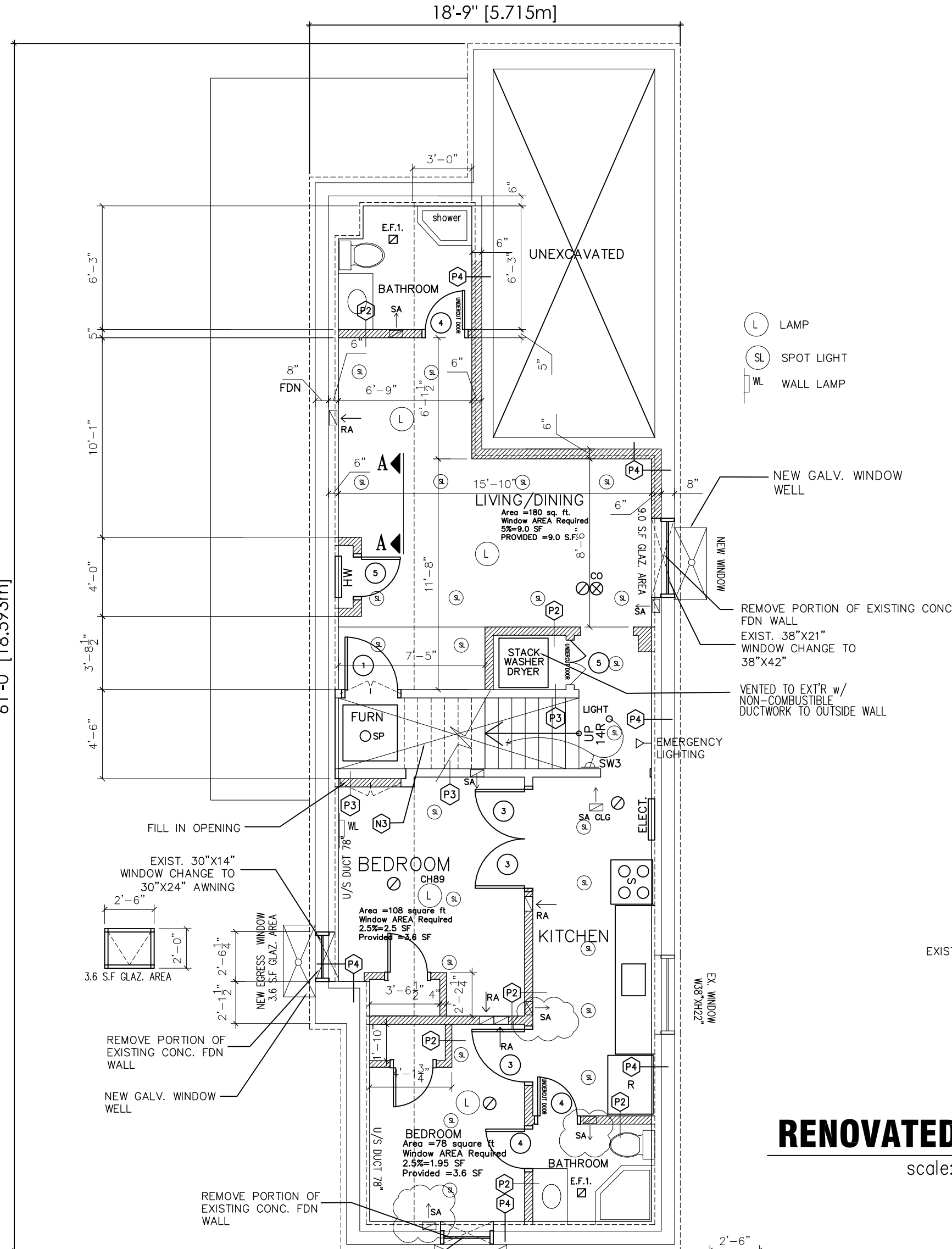

RENOVATED BASEMENT FLOOR PLAN

scale: 3/16" = 1'-0"

LEGEND:

- EXISTING WALLS
- ▨ NEW WALLS
- RENOVATED WALLS

E.F. MECHANICAL VENTILATION 150 CFM INSUL. 6" DIA. EXHAUST OUT	SA - SUPPLY AIR	RA - RETURN AIR	P1 1 LAYER 1/2" TYPE 'X' GYPSUM BOARD C/W SOUND ABORB. MATERIAL 2" X4" @ 16" O.C. SB-3 W/IB 45 MIN F.R. STC34	P2 2X4 WITH 1/2" DRY WALL BOTH SIDES
1 32X80 NEW DOOR (20 MIN RATED WITH SELF CLOSING DEVICE.)	2 2-12X80 DOOR		P1A 1 LAYER 1/2" GYPSUM BOARD C/W SOUND ABORB. MATERIAL 2" X4" @ 16" O.C. SB-3 W/IB 30 MIN F.R. STC32	P3 2X4 WITH 5/8" TYPE 'X' DRY WALL @ 16" O.C BOTH SIDES 1 HR FIRE RATED WALL (BASED ON WID SB-3)
2 32X80 NEW DOOR	3 30X80 NEW DOOR	4 24X80 NEW DOOR	P1B 2 LAYER 5/8" TYPE "X" C/W SOUND CHANNELS C/W SOUND ABORB MATERIAL 2" X4" @ 16" O.C. AND 1 LAYER OF 5/8" TYPE 'X' (BASED ON W4A SB-3 STC RATING 51)	P4 2X3 @ 16" WITH 1/2" DRY WALL WITH R20 CI SPRAYFOAM (2.75" MIN. TH.)
6 24X80 NEW DOOR			P1C 2X4 WITH 5/8" TYPE 'X' DRY WALL @ 16" O.C BOTH SIDES 1 HR FIRE RATED WALL (BASED ON W1A SB-3) STC 36	P5 2" X4" WD STUDS @ 16" O/C C/W 1/2" GYPSUM BD.
CO SMOKE ALARM INTER. CONNECTED	EXT EXISTING DOOR	SW SWITCH		
E.F.1. MECHANICAL VENTILATION 100 CFM INSUL. 6" DIA. EXHAUST OUT	SW3 3-way SWITCH			
SP-INSTALL NEW SPRINKLER HEAD IN FURNACE ROOM				

NOTES:

- DOORWAY SIZE SHALL CONFIRM TO O.B.C 9.6.3
- A SMOKE DETECTOR SHALL BE INSTALLED IN THE SUPPLY OR RETURN AIR DUCT SYSTEM WHICH SHOULD BE TURN OFF THE FUEL SUPPLY AND ELEC. POWER TO THE HEATING SYSTEM UPON ACTIVATION OF SUCH DETECTOR.
- 30 MINUTE FIRE SEPARATION 1/2" (12.7 MM) TYPE "X" GYPSUM BOARD CEILING SEE SECTION A-A

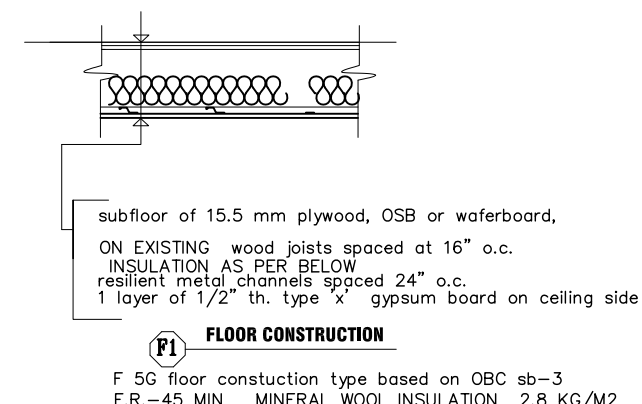

SECTION A-A

SCALE: 1/8" = 1'-0"

THE UNDERSIGNED HAS REVIEWED AND TAKES RESPONSIBILITY FOR THIS DESIGN, AND HAS THE QUALIFICATIONS AND MEETS THE REQUIREMENTS SET OUT IN THE O.B.C TO BE A DESIGNER

QUALIFICATION INFORMATION:

K. KRANAGAVARATHA (B.C.I.N) 26147

K. Kranagavaratha

REGISTRATION INFORMATION:

VARATHA DESIGN ASSOCIATES (B.C.I.N) 33937

DRAWING TITLE:
 BASEMENT RENOVATED PLAN

PROJECT:
 NEW BASEMENT APT EXISTING DWELLING TO 7 VOYSEY WAY, MARKHAM

OWNER:
 Bharathiraja Sellamuthu

ALL DRAWINGS AND RELATED DOCUMENTS ARE COPYRIGHT PROPERTY OF VARATHA DESIGN ASSOCIATES. AND MUST BE RETURNED UPON REQUEST.

REPRODUCTION OF DRAWINGS AND RELATED DOCUMENTS IN PART OR WHOLE IS FORBIDDEN WITHOUT DESIGNER'S CONSENT IN WRITING.

DRAWINGS NOT TO BE SCALED
 CONTRACTOR MUST CHECK AND VERIFY ALL DIMENSIONS ON THE SITE AND REPORT ANY DISCREPANCIES OR ERRORS BEFORE COMMENCING ANY PART OF THE WORK

THE DESIGNER HAS NOT BEEN RETAINED TO CARRY OUT GENERAL REVIEW OF THE WORK AND ASSUMES NO RESPONSIBILITY FOR THE FAILURE OF THE CONTRACTOR OR SUBCONTRACTORS TO CARRY OUT THE WORK IN ACCORDANCE WITH THE CONTRACT DOCUMENTS

MYLARS/VELUMS ARE ISSUED TO THE CLIENTS ON THE UNDERSTANDING THAT NO CHANGES ARE TO BE MADE TO THE CONTRACT DOCUMENTS WITHOUT WRITTEN CONSENT OF THE DESIGNER.

1	REVISIONS	K.V.	FEB17,21
1	BUILDING PERMIT	K.V.	FEB4,21
NO.	REVISION/ISSUED TO	BY	DATE

VARATHA DESIGN ASSOCIATES
 Architectural & Engineering Services

Varatha Ken
 Architectural Designer

TEL: (416) 284 7945

CELL: (416) 725 2041

TORONTO Ont. email: kvaratha@hotmail.com

SCALE: 3/16" = 1'-0" CAD FILE : JOB No.: 21141

DATE: FEB4,21 DWG NO: A2 OF 4

DRAWN BY: K.V.

CHECKED BY: K.V. DATE OF PRINT: FEB4,21

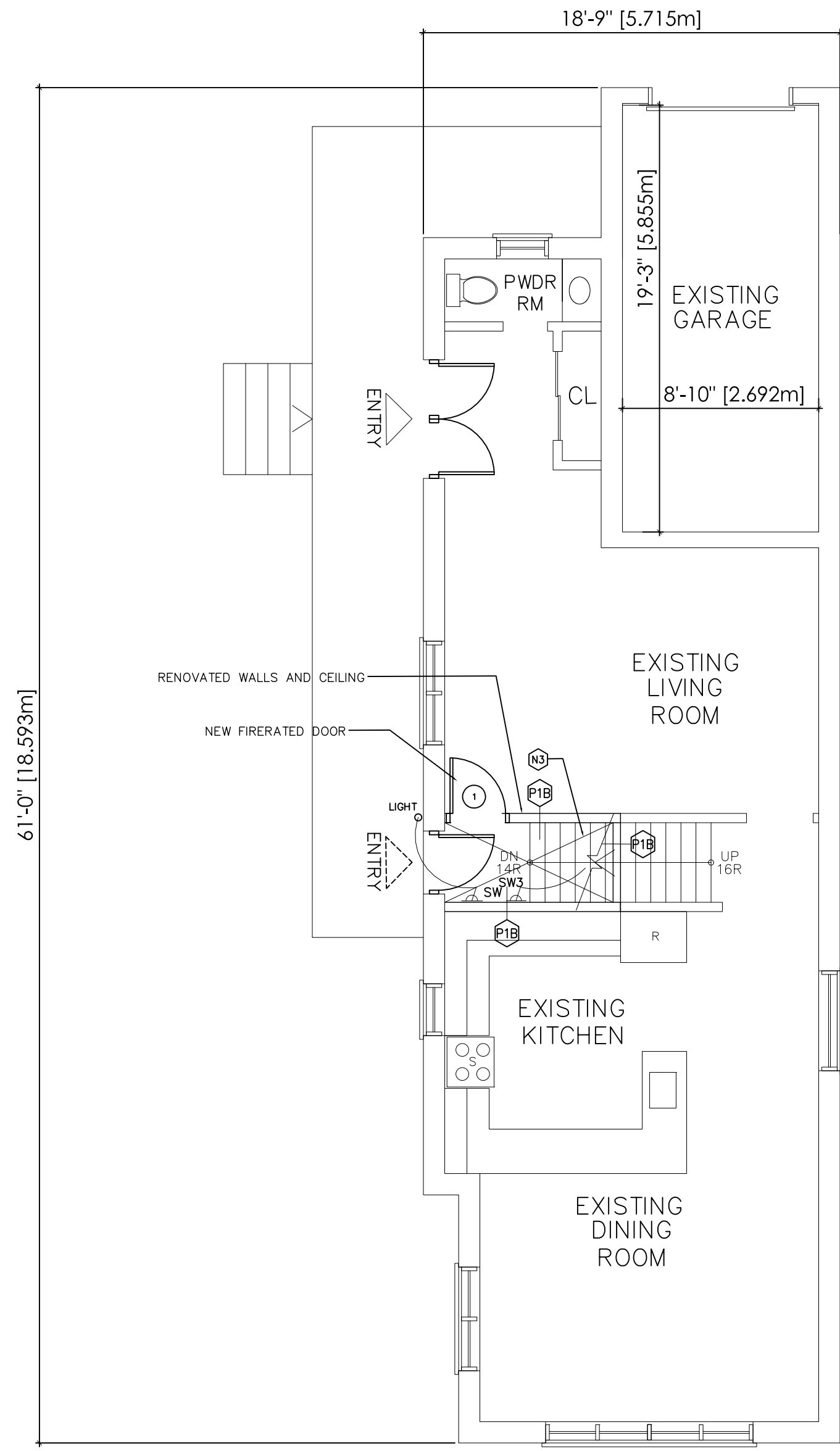

EXISTING FIRST FLOOR PLAN
 scale: 3/16" = 1'-0"

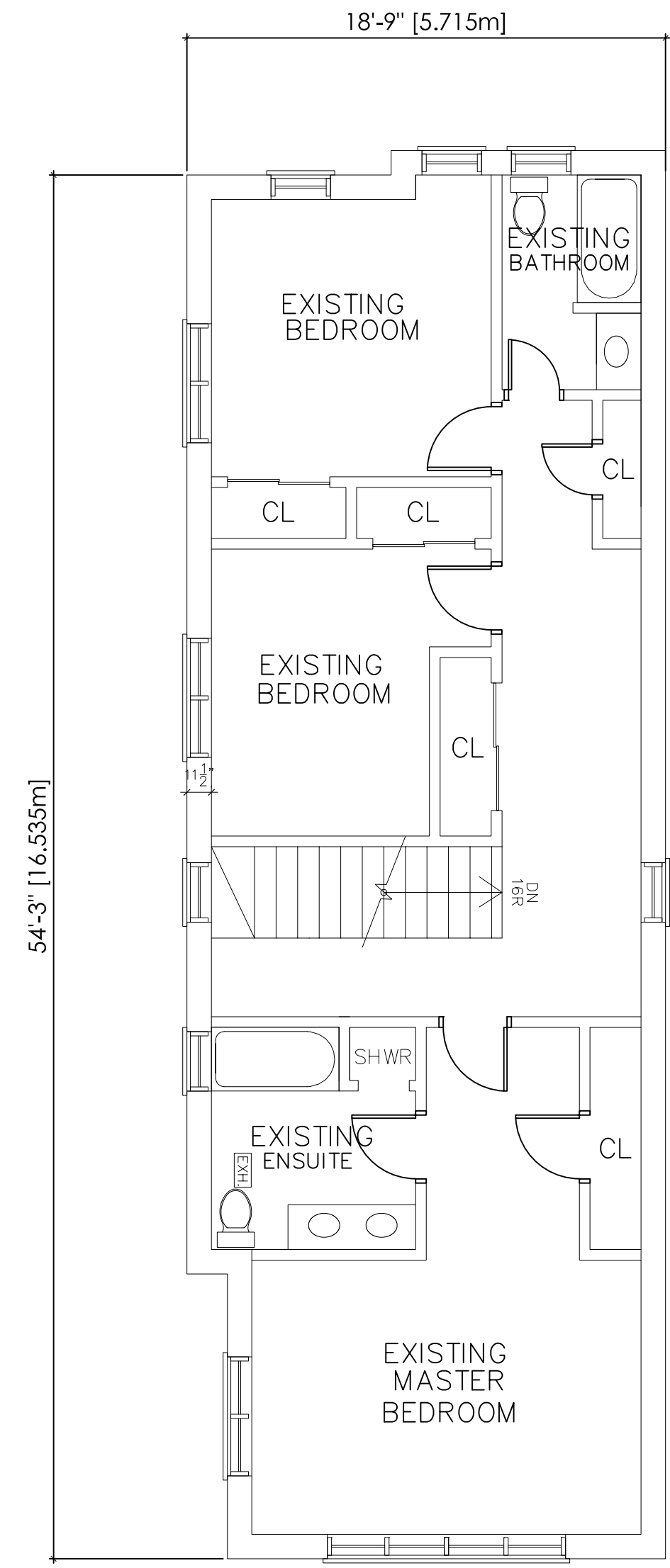

EXISTING SECOND FLOOR PLAN
 scale: 3/16" = 1'-0"

THE UNDERSIGNED HAS REVIEWED AND TAKES RESPONSIBILITY FOR THIS DESIGN, AND HAS THE QUALIFICATIONS AND MEETS THE REQUIREMENTS SET OUT IN THE O.B.C. TO BE A DESIGNER

QUALIFICATION INFORMATION:
 KRANAGAVARATHA (B.C.I.N) 26147

REGISTRATION INFORMATION:
 VARATHA DESIGN ASSOCIATES (B.C.I.N) 33937

DRAWING TITLE:	EXISTING FIRST AND SECOND FLOOR PLAN
PROJECT:	NEW BASEMENT APT EXISTING DWELLING TO 7 VOYSEY WAY, MARKHAM
OWNER:	Bharathiraja Sellamuthu

ALL DRAWINGS AND RELATED DOCUMENTS ARE COPYRIGHT PROPERTY OF VARATHA DESIGN ASSOCIATES. AND MUST BE RETURNED UPON REQUEST. REPRODUCTION OF DRAWINGS AND RELATED DOCUMENTS IN PART OR WHOLE IS FORBIDDEN WITHOUT DESIGNER'S CONSENT IN WRITING.

DRAWINGS NOT TO BE SCALED
 CONTRACTOR MUST CHECK AND VERIFY ALL DIMENSIONS ON THE SITE AND REPORT ANY DISCREPANCIES OR ERRORS BEFORE COMMENCING ANY PART OF THE WORK

THE DESIGNER HAS NOT BE RETAINED TO CARRY OUT GENERAL REVIEW OF THE WORK AND ASSUMES NO RESPONSIBILITY FOR THE FAILURE OF THE CONTRACTOR OR SUBCONTRACTORS TO CARRY OUT THE WORK IN ACCORDANCE WITH THE CONTRACT DOCUMENTS

MYLARS/VELUMS ARE ISSUED TO THE CLIENTS ON THE UNDERSTANDING THAT NO CHANGES ARE TO BE MADE TO THE CONTRACT DOCUMENTS WITHOUT WRITTEN CONSENT OF THE DESIGNER.

1	BUILDING PERMIT	K.V.	FEB4,21
NO.	REVISION/ISSUED TO	BY	DATE

VARATHA DESIGN ASSOCIATES Architectural & Engineering Services Varatha Ken Architectural Designer TEL: (416) 284 7945 CELL: (416) 725 2041 TORONTO Ont. email: kvaratha@hotmail.com			
SCALE: 3/16" = 1'-0"	CAD FILE :	JOB No.: 21141	
DATE: FEB4,21	DWG NO: A3	OF 4	
DRAWN BY: K.V.	CHECKED BY: K.V.	DATE OF PRINT: FEB4,21	

APPENDIX "C"
ORIGINAL SITE PLAN: SEPTEMBER 30, 2008

Lot No.	Model Type	Lot Area (sq.m)	Gross Floor Area (sq.m)	Gross Floor Area (percent)	Coverage (sq.m)	Coverage (percent)	Building Height (m)	Lot Frontage (m)
1L	SD-4C 'B'	430.86	174.00	40.38	99.03	22.98	9.22	20.29
1R	SD-3 'B' REV.	215.56	164.71	76.41	95.78	44.43	9.22	6.74
2L	SD-8 'C'	216.12	170.84	79.05	97.08	44.92	8.43	6.75
2R	SD-8 'C' REV.	225.60	170.84	75.73	97.08	43.03	8.43	7.05
3L	SD-8 'B'	225.60	170.84	75.73	97.08	43.03	8.43	7.05
3R	SD-8 'B' REV.	215.88	170.84	79.14	97.08	44.97	8.43	6.75
4L	SD-8 'A'	216.12	170.84	79.05	97.08	44.92	8.43	6.75
4R	SD-8 'A' REV.	225.60	170.84	75.73	97.08	43.03	8.43	7.05
5L	SD-8 'C'	225.60	170.84	75.73	97.08	43.03	8.43	7.05
5R	SD-8 'C' REV.	215.88	170.84	79.14	97.08	44.97	8.43	6.75
6L	SD-8 'B'	216.12	170.84	79.05	97.08	44.92	8.43	6.75
6R	SD-8 'B' REV.	225.60	170.84	75.73	97.08	43.03	8.43	7.05
7L	SD-8 'A'	226.24	170.84	75.51	97.08	42.91	8.43	7.07
7R	SD-8 'A' REV.	215.24	170.84	79.57	97.08	45.10	8.43	6.73
8L	SD-3 'A'	216.12	165.08	76.39	95.78	44.32	9.22	6.75
8R	SD-4C 'A' REV.	373.48	170.19	62.23	96.89	35.43	9.22	8.55
9L	SD-8 'A'	254.02	170.84	67.25	97.08	38.22	8.43	6.81
9R	SD-8 'A' REV.	253.97	170.84	67.27	97.08	38.22	8.43	6.81
10L	SD-2 'B'	347.73	149.10	42.88	86.03	24.74	8.17	11.85
10R	SD-2 'B' REV.	206.60	149.10	72.17	86.03	41.64	8.17	6.75
11L	SD-3 'B'	212.73	164.71	77.43	95.78	46.02	9.22	6.75
11R	SD-4C 'B' REV.	390.38	174.00	44.57	99.03	25.37	9.22	11.95
12L	SD-4C 'A' MOD.	318.88	149.01	46.73	86.30	27.06	8.10	11.99
12R	SD-3 'A' MOD REV.	200.43	144.83	72.26	85.16	42.49	8.10	6.75
13L	SD-2 'A'	208.15	149.10	72.33	86.03	41.73	8.17	6.75
13R	SD-2 'A' REV.	227.86	149.10	65.43	86.03	37.76	8.17	7.02
14L	SD-3 'A'	293.63	165.08	56.22	95.78	32.62	8.26	6.85
14R	SD-3 'A' REV.	239.96	165.08	68.79	95.78	39.91	8.26	6.75
15L	SD-3 'A'	239.63	165.08	68.89	95.78	39.97	8.26	6.75
15R	SD-4C 'A' REV.	396.62	170.19	42.91	96.89	24.43	9.22	9.49
16L	SD-4C 'B'	358.68	174.00	48.51	99.03	27.61	9.22	9.41
16R	SD-3 'B' REV.	259.84	164.71	63.39	95.78	36.86	9.22	6.75
17L	SD-8 'A'	243.95	170.84	70.03	97.08	38.80	8.43	6.75
17R	SD-8 'A' REV.	237.82	170.84	71.84	97.08	40.82	8.43	7.05
18L	SD-8 'B'	225.54	170.84	75.75	97.08	43.04	8.43	7.05
18R	SD-8 'B' REV.	214.47	170.84	79.66	97.08	45.27	8.43	6.75
19L	SD-8 'C'	213.36	170.84	80.07	97.08	45.50	8.43	6.75
19R	SD-8 'C' REV.	212.25	170.84	80.49	97.08	45.74	8.43	6.75
20L	SD-3 'B'	211.13	164.71	78.01	95.78	45.37	9.22	6.75
20R	SD-4C 'B' REV.	292.40	174.00	59.51	99.03	33.87	9.22	10.19
21	S-4C	344.19	174.56	50.72	99.77	28.99	7.50	9.50

REGISTERED PLAN No. 65M-
TOWN OF MARKHAM

PARKING: 2 SPACES PER LOT

LAND AREA (sq.m.): 14406.36
No. OF UNITS: 41
TOTAL GROSS FLOOR AREA (sq.m.): 6837.14



- NOTES:
- GAS METER LOCATION
 - HYDRO METER LOCATION
 - STREET SIGN
 - DENOTES UNITS WITH SPRINKLE SYSTEM
 - LIGHT POLE
 - HYDRANT
 - TRANSFORMER
 - WATER SERVICE
 - DOUBLE STM. CONNECTION
 - DOUBLE SAN. CONNECTION
 - SINGLE STM. CONNECTION
 - SINGLE SAN. CONNECTION
 - CATCH BASIN
 - EXTERIOR DOOR LOCATION (-L= No. OF RISERS)
 - SIDE WINDOW LOCATION
 - SWALE DIRECTION
 - STREET SIGN
 - CABLE TELEVISION PEDESTAL
 - BELL PEDESTAL
 - FINISHED FLOOR ELEVATION
 - UNDERSIDE FOOTING ELEVATION
 - FIN. BASEMENT FLOOR SLAB
 - TOP OF FOUNDATION WALL
 - UNDERSIDE FOOTING AT REAR
 - UNDERSIDE FOOTING AT FRONT
 - WOOD DECK REQUIRED
 - W.O.B. WALK OUT BASEMENT
 - HYDRO SERVICE LATERAL
 - 1.5m BLACK NYLON VINYL CHAIN LINK FENCE
 - EMBANKMENT 3:1 SLOPE
 - PROPOSED VALVE
 - SUPER MAIL BOX
 - PROVIDE 3/4" DIA. CLEAR STONE IN THIS AREA
 - REVERSE PLAN
 - RAIN WATER DOWNSPOUT LOCATION (DISCHARGE ON SPLASHPAD)
 - RETAINING WALL
 - ACoustical FENCE (SEE LANDSCAPE PLAN)
 - WOOD SCREEN FENCE (SEE LANDSCAPE PLAN)
 - AIR CONDITIONER REQUIRED
 - THIS LOT CONTAINS ENGINEERED FILL
 - LOT GRADING HAS BEEN REVIEWED AND APPROVED BY ENGINEER
 - CONC. LINK AT FOOTING
- NOTE: BUILDER TO VERIFY LOCATION OF ALL HYDRANTS, STREET LIGHTS, TRANSFORMERS AND OTHER SERVICES. IF MIN. DIMENSIONS ARE NOT MAINTAINED, BUILDER IS TO RELOCATE AT HIS OWN EXPENSE.
NOTE: BUILDER TO VERIFY SERVICE CONNECTION ELEVATIONS PRIOR TO CONSTRUCTING FOUNDATIONS.



KEY PLAN, NTS

NO.	REVISION	DATE	BY
1	ISSUED FOR CLIENT REVIEW	NOV.12-2007	RC
2	ISSUED FOR SPA	DEC. 18/07	RC
3	REV. AS PER CLIENT'S COMMENTS	FEB. 23-08	RC
4	REV. AS PER CLIENT'S COMMENTS	FEB. 28-08	RC
5	REV. AS PER CLIENT'S COMMENTS	MAR. 04-08	RC
6	REV. AS PER CITY'S COMMENTS	APR. 30-08	RC
7	REV. AS PER CITY'S COMMENTS	APR. 30-08	RC
8	ADD ACoustical FENCE, REDUCE MAIN ROAD TO 6.0M ROTATE LOTS 12 & 13	APR. 16-08	RC
9	ISSUED FOR SPA	APR. 30-08	RC
10	REVISED SIDEWALK AS PER ENG COMMENTS	MAY 30-08	RC
11	REVISED TOWN'S COMMENTS	MAY 30-08	RC
12	TOWN'S COMMENTS	JUNE 02-08	RC
13	ISSUED FOR PERMIT	JUNE 18-08	KL
14	COMMENTS: RE-ISSUED FOR PERMIT	JUNE 20-08	RC
15	REVISED AS PER TOWN'S COMMENTS	JUNE 25-08	RC

Drawn by: RC
Checked by: XXXX XXXX

ONTARIO ASSOCIATION OF ARCHITECTS
K. Wilson
KENNETH M. WILSON
LICENSE 2393

Viljoen Architect Inc.
BCDN: 674

300 A Wilson Avenue
Toronto, Ontario
M3H 1S8

TEL: (416) 630-2255
FAX: (416) 630-4782
EMAIL: info@viljoenarch.com

Contractor must verify all dimensions on the job and report any discrepancy to the architect before proceeding with the work. All drawings and specifications are instruments of service and the property of the architect which must be returned at the completion of the work. Drawings are NOT to be scaled.

Client: **GREAT WEST DEV.**

Project Name: **MARKHAM / ELSON MARKHAM, ONTARIO SC 07134596**

REGISTERED PLAN No. 65M-

Plans approved in accordance with site plan agreement dated: Sept 2/08

Date: Sept 2/15

Signature: [Signature]

DEVELOPMENT SERVICES
SEP 3 0 2008
RECEIVED

Scale: 1:250
Date: NOVEMBER 2007
Project No.: 07056
File No.: 07056_SP

Sheet Title: SITING & GRADING PLAN
Drawing No.: 1